



## GAS PURGING SYSTEM

- Through the utilization of strong magnets, the PurgeMaster always follows the torch.
- Due to the 360° wheels the PurgeMaster can be slid sideways and through elbows.
- No need for attaching wires or similar tools to the PurgeMaster. Simply slide it out when you are finished welding.
- Through different inserts we cover any available size of pipe.



### DOWNLOAD DXF-FILES FOR YOUR RADIUS DISCS

Make your own discs from these files



**WeldingDroid ApS**  
Haandvaerkervej 8  
6600 Vejen  
Denmark



# PURGEMASTER USER MANUAL



## DISTANCE ADJUSTMENT

a) Pay attention to the height of the 360° wheels. The height may affect the **PurgeMaster** gas coverage and the ability of the magnets to hold together. The height is adjusted by screwing the wheels more or less in.

*\*Interior part shown in illustration.*

**This configuration is for pipe welding.**

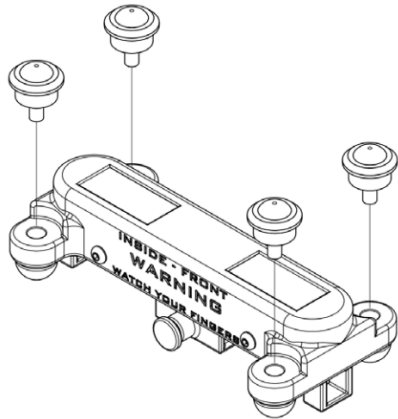

## NYLON WHEELS ARE BOLTED TO BRACKETS

b) This is done for both sides, as well as both parts - Exterior and Interior. In total **4** times. **Note** the adjustment holes. Use the holes that get PurgeMaster as close to the pipe as possible, but without it touching.

**This configuration is for tank welding.**

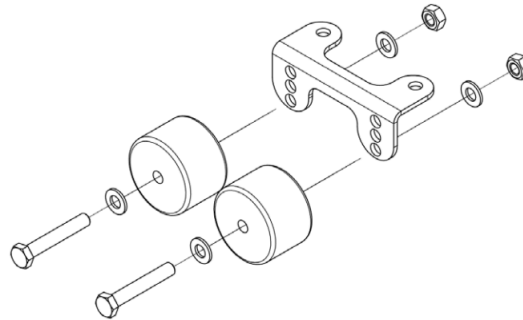

## BRACKET WITH NYLON WHEELS SCREWED TO PURGEMASTER

c) Be aware that there is a difference between the inner and outer part. There must be spacers between the bracket and the inner part. See next section for installation on interior part.

*\*Interior & Exterior part shown in illustration.*

**This configuration is for tank welding.**

